

## DefenderX Series / Sure Lock ML150™

### Product Highlights

The 1½" Sure Lock ML150™ Mechanical Lock Panel is a Architectural Standing Seam Metal Roof Panel that has all fasteners concealed for a sleek look and most importantly incredible strength and weather resistance. This Metal Roofing Panel provides a traditional look and utilizes mechanical seaming to enhance design needs. The 1½" Mechanical Lock Panel can be installed using an expansion/floating or fixed clip system. This panel can be single or double locked and is available in a variety of standard widths and colors, but can be customized to the needs that you are looking for. This panel can be rollformed on-site or at our facility in Rigby, Idaho. Rollforming on-site can help reduce shipping costs and damage to the panels in the shipping process.

#### On-Site Rollforming Available for this Panel

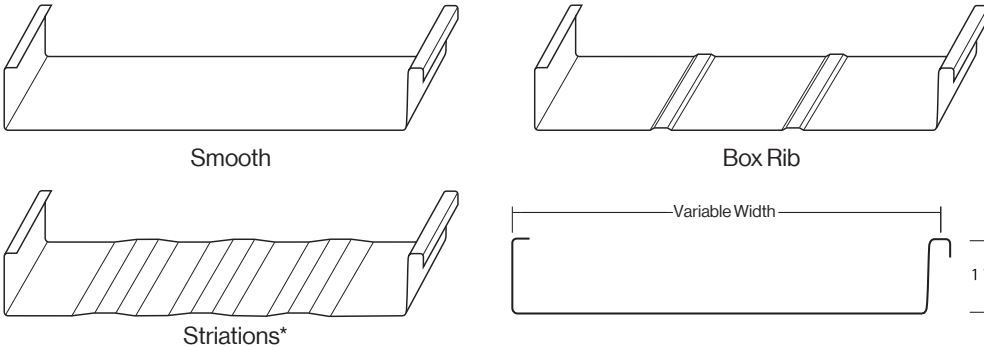

### Materials Available

26ga, 24ga, 22ga Steel

0.032" Aluminum

16oz, 20oz Natural Copper

0.7mm, 0.8mm Natural Zinc

WeatherXL™ SMP by Sherwin-Williams®  
Fluropon® by Sherwin-Williams®PVDF (Kynar 500®)

Textured / Crinkle (Rawhide)  
Vintage®  
Western Rust  
Cor-Ten AZP® Raw  
Copper-Ten® Raw  
Galv-Ten® Raw  
Galvalume® (Acrylic Coating)  
Galvanized  
Electro-Galvanized  
Galvannealed  
Bonderized Weathering Steel  
ReziBond® Weathering Steel  
Cold Rolled Weathering Steel  
A606-4 (Corten) Weathering Steel  
Hammered Copper  
Stainless Steel  
Perforated  
(See Color Guide(s) for Many More Options)

\*Recommended Option

### Product Specifications

<b>Applications:</b>	Roofing, Wall, Soffit, Fascia, Ceiling, Interior	<b>Thickness:</b>	24ga High Quality Grade D Steel (yield strength of 50,000 psi) (optional) 26ga, 22ga (Please inquire for more available thicknesses)
<b>Coverage:</b>	Standard Widths: 12½", 16½", 20½" (Custom Widths from 7" to 27½")	<b>Coatings:</b>	Fluropon® by Sherwin-Williams® PVDF (Kynar 500® or Hylar 5000®) Fluropon® by Sherwin-Williams® PVDF 3 Coat (Kynar 500® or Hylar 5000®) WeatherXL™ SMP by Sherwin-Williams® (Silicone Modified Polyester) Super Dynapon by Sherwin-Williams® (ceramic pigment polyester coating) AZ55 Galvalume® with Acrylic Coating
<b>Rib Heights:</b>	1" Tall Standing Seam Rib	<b>Substrate:</b>	G90 Galvanized Grade D (yield strength of 50,000 psi) (optional) AZ50, AZ55 Galvalume®, G100 Galvanized (optional) Embossing Available
<b>Fastening System:</b>	Concealed Fastening System using Fixed or Expansion Clips (Seamer Required)	<b>Fielding Conditions:</b>	Oil Canning is inherent in all light gauge metal products & is not a cause for rejection. Visit <a href="http://www.briggssteel.com/oilcanning">www.briggssteel.com/oilcanning</a> for more information.
<b>Length(s):</b>	Maximum Length of 150' + Minimum Length of 3'0"	<b>Accessories:</b>	Trim, Custom Trim, Fasteners, Sealant, Closures, Venting, Pipe Flashings, Underlayment, Snow Retention, Polycarbonate Panels, Many Tools.
<b>Minimum Slope:</b>	½:12 Pitch or greater with thermally applied butyl sealant & recommended self-adhered underlayment covering entire substrate 3:12 Pitch or greater (optional: recommended thermally applied butyl sealant)	<b>More Details:</b>	For more information about this profile, please visit <a href="http://www.BriggsSteel.com">www.BriggsSteel.com</a>
<b>Substrate Install:</b>	Solid		
<b>Ribbing Options:</b>	Smooth, Striations, Box Ribs, Pencil Ribs		
<b>Curving:</b>	Curving Panels Available on-site or in facility. Curved Trim also Available.		



SHERWIN-WILLIAMS  
Coil Coatings

Dura Coat  
PERFORMANCE  
An Axalta Coating Systems Company

### Protective Film Available Upon Request

Note: For standard color selection, consult the current Briggs Steel Color Selection Guides. Custom colors are available upon request.  
\*\*Actual coverage may vary slightly due to the characteristics of the steel.

For more load table information, please contact Briggs Steel sales representative.

Live Load (PSF)	30"	36"	42"	48"	54"	60"
2 or More Spans	152	105	78	61	47	38
3 or More Spans	180	124	90	70	56	45

\*Based on 29ga Grade E Steel (yield strength of 80,000 psi)

#### Testing

Meets Requirements for:  
UL 580 Class 90 & ASTM E1592 Uplift Resistance  
UL 2218 Class 4 Impact Resistance  
UL 263 & UL 790 Class A Fire Resistance  
ASTM E283 & ASTM E1680 Air Infiltration  
ASTM E331 & ASTM E1648 Water Penetration

#### Typical Fastener Spacing

- 24" on center max for 7¼" to 11¼" panel widths  
- 24" on center max for 12" to 15¾" panel widths  
- 18" on center max for 16" to 19¾" panel widths

\*The above diagrams are the typical fastener pattern. However pattern & spacing may not be appropriate for all applications. Consult local building codes and/or professional engineer for alternative use.

Install This Direction →

← Prevailing Wind

